

MERLO P 72.10

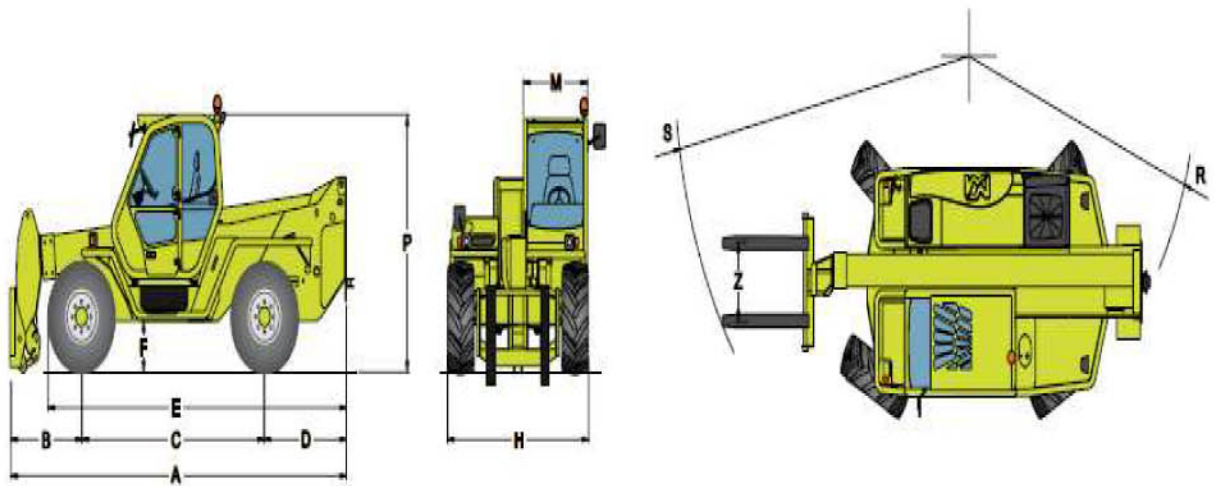

PANORAMIC	P 72.10	
Weight		
Total empty weight (with forks)	kg	10500
Performance		
Rated maximum load	kg	7200
Maximum lift height	m	9.55
Maximum forward reach	m	5.5
Lift height at full capacity	m	6
Reach at full capacity	m	1.6
Capacity at full lift height	kg	4000
Capacity at full forward reach	kg	2000

PANORAMIC	P 72.10	
Dimensions		
A	mm	5345
B	mm	1235
C	mm	2875
D	mm	1300
E	mm	4645
F	mm	480
H	mm	2240
M	mm	995 ¹⁾
P	mm	2440
R	mm	3950
S	mm	4970
Z	mm	850

¹⁾ Useful internal width

WINNER HANDLING

SUSSEX: 01903 230700

SURREY: 01483 456789

EMAIL: SALES@WINNERHANDLING.CO.UK

MERLO P 72.10

P 72.10

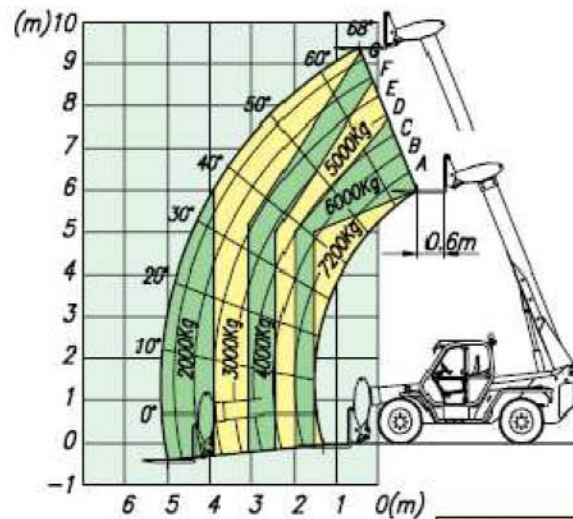

EN 1459/A

Cab

- Complies with ISO 3449 (FOPS) and ISO 3471 (ROPS) standards.
- "4 x 1" electro-proportional joystick.

Boom

- Telescopic, with sections sliding on adjustable low-friction pads.
- Hydraulic extension mechanism, hydraulic pipes and electrics are totally enclosed within the boom assembly to ensure maximum protection and reliability.
- Integral boom side-shift mechanism.

Quick-attach carriage

- The Tac-Lock quick attachment fitting system is hydraulically controlled from the cab.
- Standard double-acting hydraulic service, with quick couplings, for the operation of hydraulically powered attachments.

Frame levelling

- Hydraulically operated from the cab. Frame levelling $\pm 10\%$.

Forks

- Floating type. Length 1200mm. Section 150 x 60mm.
- Fork spacing is manually adjustable between 450 and 1010mm.

Steering

- Four drive/steer wheels, with automatic wheel synchronisation in the event of any misalignment and selection of three steering modes from the cab.

Engine

- Direct injection, water cooled, 4 cylinder Perkins Euro 2 turbo diesel engine producing 74.5kW-101HP at 2400rpm (97/68/CE).

Transmission

- Hydrostatic, with electronically controlled variable displacement pump.
- Continuous and automatic speed variation, from zero to maximum speed, solely with the accelerator pedal.
- Two-speed mechanical range gearbox.
- Inching-Control pedal to proportionately reduce travel speed whilst maintaining high engine speed for hydraulic operation e.g. during loading operations.
- Finger-Touch system makes it possible to change between forward and reverse

direction with the driver keeping both hands firmly on the steering wheel.

- Permanent four-wheel drive.
- Portal axles ensuring excellent ground clearance.

Braking system

- Disc service brakes on all 4 wheels, hydraulically operated and acting on the differential output shafts.
- Disc parking brake with automatic locking feature and hydraulic release control, acting on the main transmission shaft.

Hydraulic system

- Variable delivery Load Sensing pump.
- Maximum operating capacity: 100lpm.
- Working pressure: 210bar.

Electrics

- 12V system with 100Ah battery and 90A alternator.
- Full road lighting and rotating beacon.
- Manual battery isolator switch (optional automatic switch).

Service capacities

- Hydraulic oil: 95 litres
- Diesel fuel: 155 litres
- Hydrostatic oil: 12 litres
- Engine oil: 8.5 litres
- Coolant: 12 litres

Tyres

- 400/70-20 (P 60.10) and 18-19.5 (P 72.10).

Available options

- Rear axle differential lock.
- Automatic battery isolator.
- Manual control air conditioning.
- Windscreen wiper on the roof window.
- Four working lights on the cab (two front lights and two rear).
- Pneumatic seat.
- BSS boom suspension system.
- Roof and front window mounted sun blinds.

WINNER HANDLING

SUSSEX: 01903 230700

SURREY: 01483 456789

EMAIL: SALES@WINNERHANDLING.CO.UK