

# MERLO P 34.7

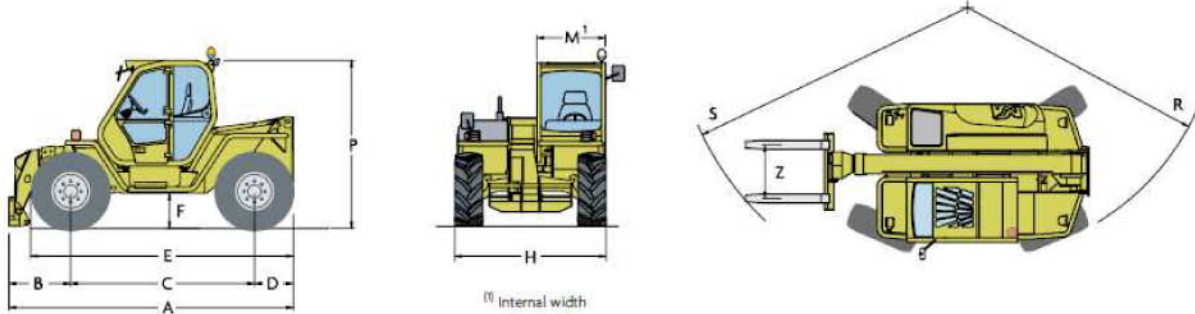

## PANORAMIC

## P 34.7 P 34.7 PLUS

### Weight

Total empty weight (with forks)	kg	6600
---------------------------------	----	------

### Performance

Rated maximum load	kg	3400
Maximum lift height	m	7
Maximum forward reach	m	3.65
Lift height at full capacity	m	7
Reach at full capacity	m	1.5
Capacity at full lift height	kg	3400
Capacity at full forward reach	kg	1350
Low emission (Euro 2) turbo engine		turbo
Power at 2400rpm (97/68/CE)	kW/HP	74.9/102

### Speed ratios

1 <sup>st</sup> gear	kph	7/11 <sup>(1)</sup>
2 <sup>nd</sup> gear (self-limiting maximum speed)	kph	25/40 <sup>(1)</sup>

### Dimensions

A	mm	4180
B	mm	905
C	mm	2700
D	mm	570
E	mm	3865
F	mm	565
H	mm	2230
M	mm	995
P	mm	2475
R	mm	3985
S	mm	4670
Z	mm	850

## WINNER HANDLING

SUSSEX: 01903 230700

SURREY: 01483 456789

EMAIL: SALES@WINNERHANDLING.CO.UK

# MERLO P 34.7

P 34.7 - P 34.7 PLUS

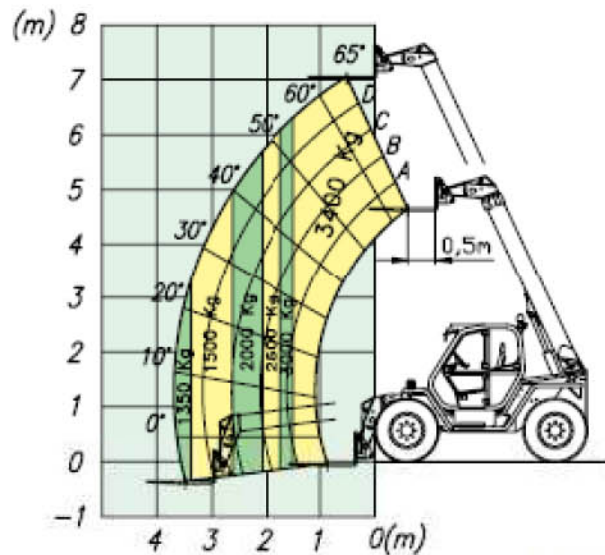

EN 1459/B

## **Cab**

- Complies with ISO 3449 (FOPS) and ISO 3471 (ROPS) standards.
- '4 x 1' electro-mechanical joystick with roller-operated proportional control of extension and auxiliary services.

## **Boom**

- Telescopic, with sections sliding on adjustable low-friction pads.
- Hydraulic extension mechanism, hydraulic pipes and electrics are totally enclosed within the boom assembly to ensure maximum protection and reliability.
- Integral boom side-shift mechanism (on some models).

## **Quick-attach carriage**

- The Tac-Lock quick attachment fitting system is hydraulically controlled from the cab.
- Standard double-acting hydraulic service, with quick couplings, for the operation of hydraulically powered attachments.

## **Frame levelling (on some models)**

- Hydraulically operated from the cab.

## **Forks**

- Floating type. Length 1200mm. Section 130 x 50mm.
- Fork spacing is manually adjustable between 450 and 1050mm.

## **Steering**

- Four drive/steer wheels, with automatic wheel synchronisation in the event of any misalignment and selection of three steering modes from the cab.

## **Engine**

- Direct injection, water cooled 4 cylinder Deutz Euro 2 turbocharged diesel engine producing 74.9kW (102HP) at 2400rpm (97/68/CE).

## **Transmission**

- Hydrostatic with electronically controlled variable displacement pump.
- Continuous and automatic speed variation, from zero to maximum speed, solely with the accelerator pedal.
- Two-speed mechanical range gearbox.
- Inching-Control pedal to proportionately reduce travel speed whilst maintaining high engine speed for hydraulic operation e.g. during loading operations.
- Finger-Touch system makes it possible to change between forward and reverse

- direction with the driver keeping both hands firmly on the steering wheel.

- Permanent four-wheel drive.

- Portal axles ensuring excellent ground clearance.

## **Braking system**

- Disk service brakes on all 4 wheels, hydraulically operated and acting on the differential output shafts.
- Disk parking brake with automatic locking feature and hydraulic release control, acting on the main transmission shaft.

## **Hydraulic system**

- Gear pump equipped system.
- Maximum operating capacity; 100lpm.
- Working pressure: 210bar.

## **Electrics**

- 12V system with 100Ah battery and 90A alternator.
- Full road lighting and rotating beacon.
- Manual battery isolator switch (optional automatic switch).

## **Service capacities**

- Hydraulic oil: 105 litres
- Diesel fuel: 155 litres
- Hydrostatic oil: 12 litres
- Engine oil: 8.5 litres
- Coolant: 12 litres

## **Tyres**

- 405/70-24 (optional 405/70-20 or 460/70LR24).

## **Available options**

- Front and/or rear axle differential lock.
- Automatic battery isolator.
- Manual control air conditioning.
- Windscreen wiper on the roof window.
- Four working lights on the cab (two front lights and two rear).
- Pneumatic seat.
- Roof and front window mounted sun blinds (standard on PLUS models).
- BSS boom suspension system or EAS front axle suspension.

**WINNER HANDLING**

SUSSEX: 01903 230700

SURREY: 01483 456789

EMAIL: SALES@WINNERHANDLING.CO.UK